



newviolence
JOSHUA WEBB
29JUNE - 27JULY 08

THE STAGE OF TERROR

Jessyca Hutchens

In the final scene of Werner Herzog's *Aguirre, Wrath of God*, we see the figure of the crazed Spanish soldier, Lope de Aguirre, maniacally pacing around the dishevelled remains of his raft as it continues to float down the Amazon River on a now pointless journey to find El Dorado. In delusional ecstasy he raves: "We'll stage history as others stage plays."

In *New Violence*, Webb stages a similar scene, one that not only encapsulates an historical moment of madness and folly, but which alludes to a kind of cinematic reverence for such moments (*Apocalypse Now*, *Citizen Kane*). He presents us with the end, the final scene. We witness a suicidal soldier heading towards an ephemeral, ungraspable red drape, it's constantly morphing form imbuing the space with an inertial momentum that is also implied in the structure of the "floating" oil barrel raft. Without a preceding narrative, or a finite point at which to "roll credits" Webb's ending is set adrift. He presents a space that continuously performs the quality of endings while also refusing closure.

New Violence, which follows in the wake of *New Disorder* (The Ice-Cream Factory, 2007) and *The Gift* (PICA, 2006), is the third show by Webb to create such a space of portentous cinematic drama. It is also the third re-incarnation of his work, *The Gift*, a Styrofoam monument that Webb continues to offer up as potlatch to his audiences. This new instalment sees the plinth rendered in concrete (a clever disguise for its lightweight foam frame) and aptly re-named *Trojan Horse*, a warning to his audience that an artistic gesture is never empty.

These works are staged theatrical images. They are, particularly in the case of *Trojan Horse*, faked, and obviously so. Unlike the images of war and terror that proliferate in mass media, purporting to signify the “return of the real” in their preference for the graphic and the grotesque, Webb does not attempt to approximate reality. Instead, he creates fantasy from the images that fuel our obsession with reality, namely those related to global politics and the war on terror. Ultimately his pieces would be more at home in a B-grade horror film than a realistic war epic. And this is precisely the point. That the true “horror” of our present day image production, is our renewed belief in the reality of images.

Webb is engaged in a process of actively historicizing the images of terror, scrambling a host of didactic political images (the oil barrels, the UN soldier, the red-curtain), with the most potent methods of historical glorification (monument building, war propaganda and film-making). By reviving the aesthetics of the post-apocalyptic landscape and the art of war glorification, he creates an advertisement for the new world order that reveals all political history as effectively staged.

1

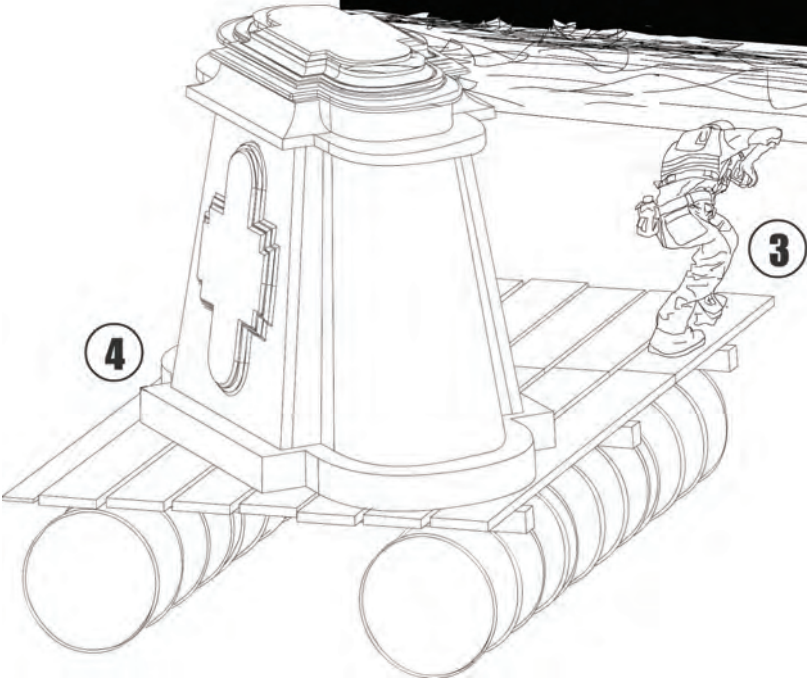
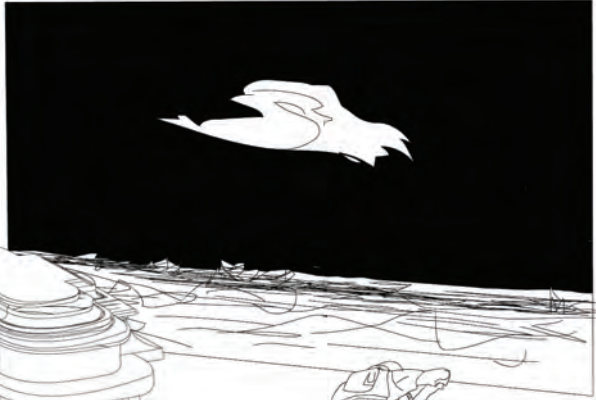

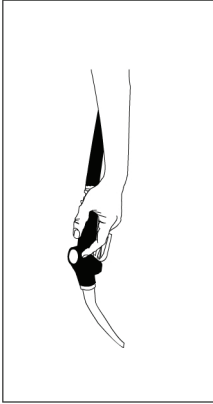

2

1. *New Dawn*. 2008
6mins looped. High Definition digital Video.
(2OFF 2)
\$13000

2. *New Violence*. 2008
Digital print of archival paper. 1000x1520mm.
\$1200

3. *The Diplomat*. 2008
Styrofoam, poly concrete-resin found objects.
\$4000

4. *Trojan Horse*. 2008
Styrofoam, poly concrete-resin, concrete.
\$14000

JOSHUA WEBB

Academic Qualifications

- 2010 MFA, Rhode Island School of Design, Providence, Rhode Island (USA)
- 2006 Advanced diploma of Three Dimensional Animation . E-tafe, East Perth, W.A.
- 2005 Bachelor of Arts. (Art) 1st Class Honours, Curtin University of Technology, Perth W.A.
- 2001 Bachelor of Arts. (Visual Arts) Curtin University of Technology, Perth W.A.
- 1998 Graduation Kalamunda Senior High School (K.S.H.S.) Perth W.A.
- 1998 Graduation Special Art Program (K.S.H.S.) Perth W.A.

Exhibitions Solo

- 2008 Galerie Düsseldorf, 9 Glyde St, Mosman Park, WA. New Violence. June. 29
- 2008 Meet Factory Gallery, Prague, Czech Republic. New Violence. Apr. 25.

Exhibitions Group

- 2008 Australian Centre for Photography, Oxford ST, Paddington, NSW. HIJACKED. Jun. 13
- 2007 Green Hills Gallery, Kings Street, Perth, W.A. Perrine Contemporary Art Prize. Nov. 24
- 2007 The Ice Cream Factory, Perth, W.A. New Disorder. Nov.16
- 2007 PICA, Perth, W.A. Bank West Art Prize. Oct.31
- 2007 Perth Town Hall, Perth, W.A. City of Perth Art Award. Sept
- 2006 Breadbox Gallery, Perth, W.A. Salon refuse. Nov.8
- 2006 Galerie Düsseldorf, 9 Glyde St, Mosman Park, WA. 30th Anniversary Show. Nov.12
- 2006 PICA [Perth Institute of Contemporary Art] BECKON, Aug.17
- 2006 John Curtin Gallery, Curtin University of Technology. Perth, WA. DOFA06. May.12
- 2006 Next Building, Perth, WA. Office6000. Mar.25
- 2005 Curtin University of Technology, Perth, W.A. I was just leaving, Dec. 7
- 2005 PICA [Perth Institute of Contemporary Art] City of Perth Art Award. Nov. 24
- 2005 Keith+Lottie Gallery , Perth W.A. Post-it. Oct. 5
- 2005 Mulberry Farm, Perth, W.A. Sun Shine people, Collaborative project, Poolside collective [Aidan Broderick, Tess McNamara & Joshua Webb] Jan.1
- 2004 Belmont Race Track, Perth, W.A. Science Fiction, Nov. 20
- 2004 Breadbox Gallery, Perth, W.A. Coalesce, Collaborative installation [Aidan Broderick, Carl Fraunschiel & Joshua Webb] July.24
- 2004 Hudson Gallery, Perth, W.A. POOLSIDE 500mg, Collaborative project, Poolside collective [Aidan Broderick, Tess McNamara & Joshua Webb] July.8-25
- 2004 Breadbox Gallery, Perth, W.A. IN HAPPINESS, Collaborative installation, Poolside collective [Aidan Broderick, Tess McNamara & Joshua Webb] Jan. 7-31
- 2003 Virus Lounge, Perth, W.A. Love Tester, Collaborative installation, as Poolside Manifesto [Aidan Broderick, Tess McNamara & Lucy Morely & Joshua Webb] Mar. 28-Apr. 20
- 2002 Rhodes Hotel, Perth, W.A. HOTEL 6151, Nov.1-3
- 2001 Curtin University School of Art, Perth, W.A. ZERO 1, Dec.7-16
- 2001 PICA [Perth Institute of Contemporary Art] Downsize, Nov.21- Dec.16
- 1999 Art Gallery of Western Australia, Year 12 Perspectives, Feb.18-Mar. 28

Prizes Grants Awards Residences

- 2008 Meet Factory International Atelier Residency Program, Prague, Czech Republic.
- 2007 The Anne & Gordon Samstag International Visual Arts Scholarship
- 2007 City of Perth Art Award: commendation award
- 2006 ArtsWA Fellowship
- 2006 Galerie Dusseldorf Scholarship
- 2006 ArtsWA New Concepts Grant. Financial support for sculptural project: Beckon exhibition at PICA
- 2005 British Council Mordant Art Award Finalist.
- 2001 Curtin University of Technology Division of Humanities School of Art Prize
- 2004 Quick Response Grant. Arts W.A. Financial support for Collaborative project: Hudson Gallery, Perth, W.A. POOLSIDE 500mg, Poolside collective [Adain Broderick, Tess McNamara] July.8-25
- 2004 Perth Institute of Contemporary Art, Studio Residency JOSH'S HOMEWORK, Feb.1-Apr. 11

Collections

- 2007 Perrine Contemporary Art Collection, Perrine Architects. Perth WA
- 2006 John Curtin Gallery collection. Curtin University of Technology. Perth WA

Selected Bibliography

- Alach.F. 2002, Hotel6151, Artlink, vol.23, no.1, p.90
- Currey.S. Fraunschiel.F. & Trethewey.T. 2004, oasis of false promise... ISO Magazine, Issue 1, p.1-2
- Dean .B. 2003, Art to bump into. Real Time, Vol. Jun-July, No.55, p.36
- Fraunschiel.F. & Trethewey.T. 2004, I purchase a lifestyle foe \$2.50, its just not working out for me... ISO Magazine, Issue 2, Section 2 p.3-5
- Martin-Chew.L. 2007, Alternative Realities.
The Anne & Gordon Samstag International Visual Arts Scholarship Catalogue.
- Michael.G. 2003, Game of Love, X-press, No.248, p.14
- O'Meagher.G. Poolside Manifesto, Curve, Issue 3, p.52-54
- Snell.T. 2006. Office politics put into perspective. The Australian, Mar.28, p.17
- Snell.T. 2006.OFFICE6000. ArtLink, Vol 26. no3
- Spencer.R. 2005, Is this the new dystopia? The West Australian, Nov.23, p.6-7
- Spencer.R. 2005, Money for art's sake. The West Australian, Dec.17, p.13
- City of Perth Art Award. 2005, Exhibition catalogue PICA
- I was just leaving. 2005, Perth, Curtin University School of Art
- ZERO1: Western Australian art. 2001, Perth, Curtin University School of Art



Special thanks to:
Ben Kovacs y
Douglas & Magda
Jessyca Hutchens
Julian Stadon
Paul Caporn
Peter Blamie
The Webb family

Vince Ross
AUDIO WORLD



Department of Culture and the Arts
Government of Western Australia

samstag

GALERIE DÜSSELDORF

9 Glyde Street Mosman Park

WA. Australia. 6012

PH: +618 9384 0890

gd@galeriedusseldorf.com.au

www.galeriedusseldorf.com.au

GALLERY HOURS: Wed-Fri 11-5pm Sun 2-5pm